

General Description

The ZM062N03M combines advanced trench MOSFET technology with a low resistance package to provide extremely low $R_{DS(ON)}$. This device is ideal for load switch and battery protection applications.

Features

- Advance high cell density Trench technology
- Low $R_{DS(ON)}$ to minimize conductive loss
- Low Gate Charge for fast switching
- Low Thermal resistance

Application

- MB/VGA Vcore
- SMPS 2nd Synchronous Rectifier
- POL application
- BLDC Motor driver

Product Summary

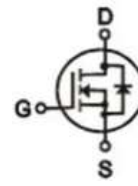

$V_{DS} = 30V$

$R_{DS(ON)} = 6.2m\Omega$

$I_D = 40A$

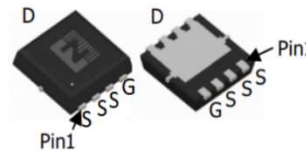

DFN3 x 3

Ordering Information:

Part NO.	ZM062N03M
Marking	062N03
Packing Information	REEL TAPE
Basic ordering unit (pcs)	5000

Absolute Maximum Ratings ($T_C = 25^\circ C$)

Parameter	Symbol	Rating	Unit
Drain-Source Voltage	V_{DS}	30	V
Gate-Source Voltage	V_{GS}	± 20	V
Continuous Drain Current	$I_{D@T_C=25^\circ C}$	40	A
	$I_{D@T_C=75^\circ C}$	30.4	A
	$I_{D@T_C=100^\circ C}$	25.2	A
	$I_{D@T_A=25^\circ C}$	12.2	A
	$I_{D@T_A=70^\circ C}$	9.7	A
Pulsed Drain Current ^①	I_{DM}	100	A
Total Power Dissipation ^②	$P_{D@T_C=25^\circ C}$	25	W
Total Power Dissipation	$P_{D@T_A=25^\circ C}$	1.8	W
Operating Junction Temperature	T_J	-55 to 150	$^\circ C$
Storage Temperature	T_{STG}	-55 to 150	$^\circ C$
Single Pulse Avalanche Energy	E_{AS}	210	mJ

•Thermal resistance

Parameter	Symbol	Min.	Typ.	Max.	Unit
Thermal resistance, junction - case ^②	R _{thJC}	-	-	5.0	° C/W
Thermal resistance, junction - ambient	R _{thJA}	-	-	70	° C/W
Soldering temperature, wavesoldering for 10s	T _{sold}	-	-	265	° C

•Electronic Characteristics

Parameter	Symbol	Condition	Min.	Typ	Max.	Unit
Drain-Source Breakdown Voltage	BV _{DSS}	V _{GS} =0V, I _D =250uA	30			V
Gate Threshold Voltage	V _{GS(TH)}	V _{GS} =V _{DS} , I _D =250uA	1.2		2.5	V
Drain-Source Leakage Current	I _{DSS}	V _{DS} =30V, V _{GS} =0V			1.0	uA
Gate- Source Leakage Current	I _{GSS}	V _{GS} =±20V, V _{DS} =0V			±100	nA
Static Drain-source On Resistance	R _{DS(ON)}	V _{GS} =10V, I _D =20A		6.2	8.0	mΩ
		V _{GS} =4.5V, I _D =10A		10	12	mΩ
Forward Transconductance	g _{FS}	V _{DS} =25V, I _D =10A		9		s
Source-drain voltage	V _{SD}	I _S =20A			1.28	V

•Electronic Characteristics

Parameter	Symbol	Condition	Min.	Typ	Max.	Unit
Input capacitance	C _{iss}	V _{DS} =25V f = 1MHz	-	1150	-	pF
Output capacitance	C _{oss}		-	235	-	
Reverse transfer capacitance	C _{rss}		-	120	-	

•Gate Charge characteristics(T_a = 25°C)

Parameter	Symbol	Condition	Min.	Typ	Max.	Unit
Gate Resistance	R _g	f = 1MHz		1.8		Ω
Total gate charge	Q _g	V _{DD} =15V I _D = 20A V _{GS} = 10V	-	12	-	nC
Gate - Source charge	Q _{gs}		-	4	-	
Gate - Drain charge	Q _{gd}		-	6	-	
Turn-ON Delay time	t _{D(on)}	V _{GS} =10V, V _{DS} =15V		4.5		ns
Turn-ON Rise time	t _r	R _G =3.3Ω, I _D =15A		12		ns

Turn-Off Delay time	$t_{D(off)}$		26	ns
Turn-Off Fall time	t_f		7.5	ns

Note: ① Pulse Test : Pulse width $\leq 300\mu s$, Duty cycle $\leq 2\%$;

② Device mounted on FR-4 substrate PC board, 2oz copper, with thermal bias to bottom layer 1inch square copper plate;

Fig.1 Power Dissipation

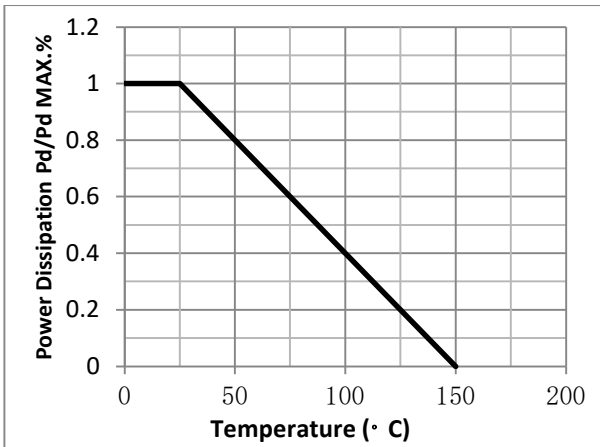

Fig.2 Typical output Characteristics

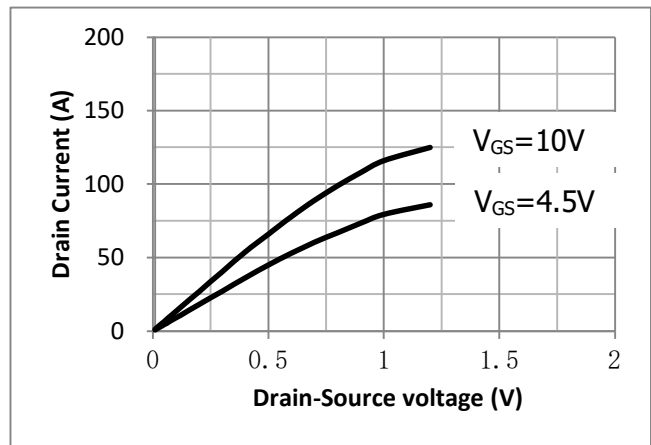

Fig.3 Threshold Voltage V.S Junction Temperature

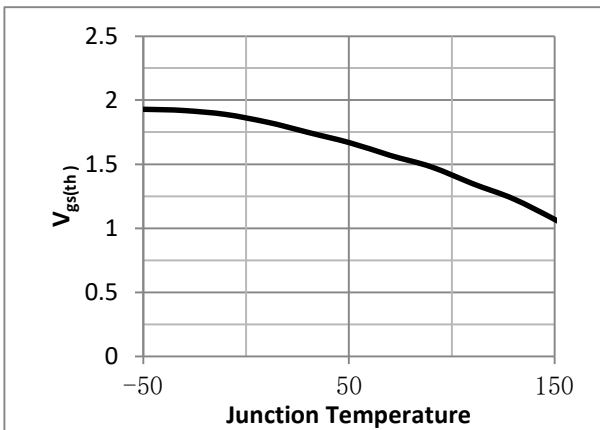

Fig.4 Resistance V.S Drain Current

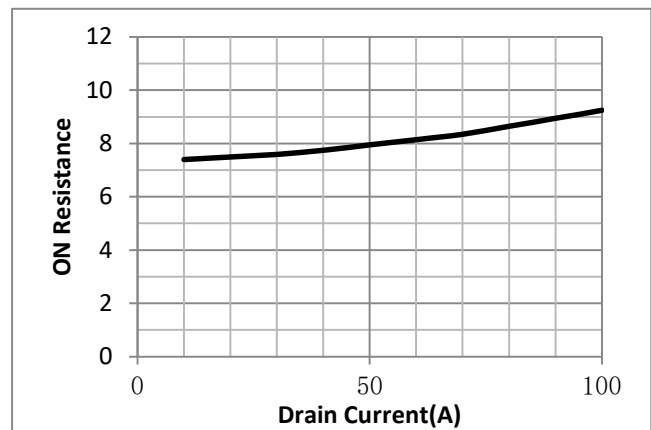

Fig.5 On-Resistance VS Gate Source Voltage

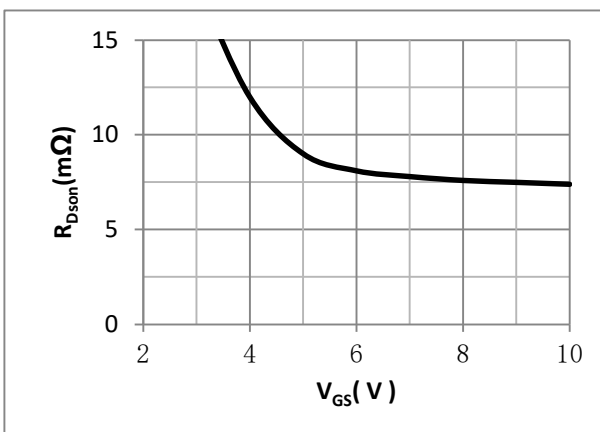

Fig.6 On-Resistance V.S Junction Temperature

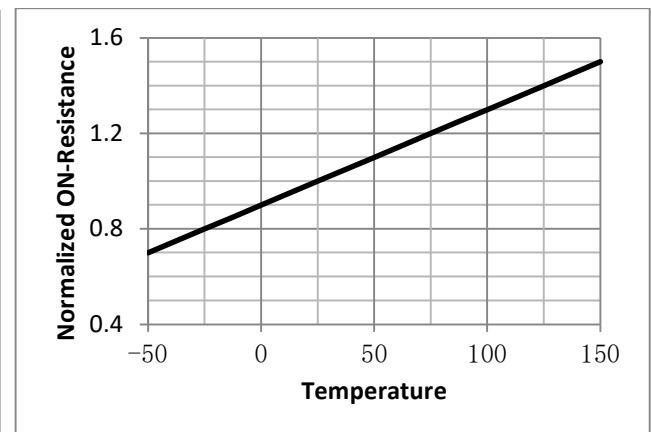

Fig.7 Gate Charge Measurement Circuit

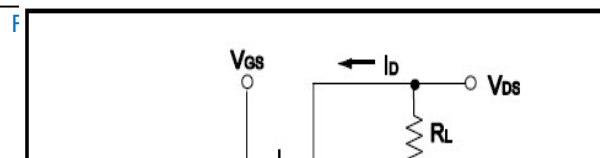

Fig.8 Gate Charge Waveform

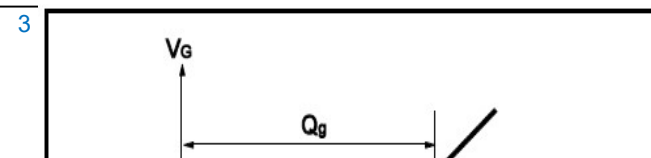

Fig.9 Switching Time Measurement Circuit

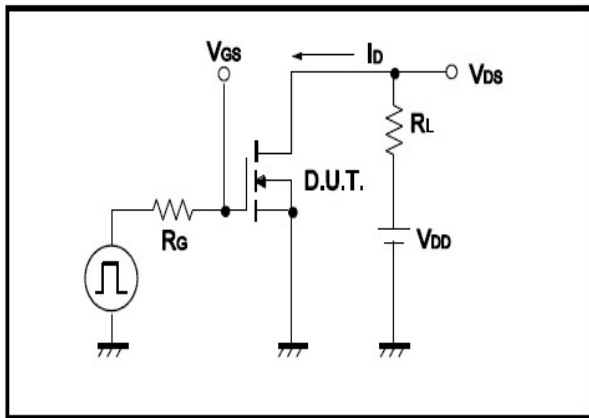

Fig.10 Switching Time Waveform

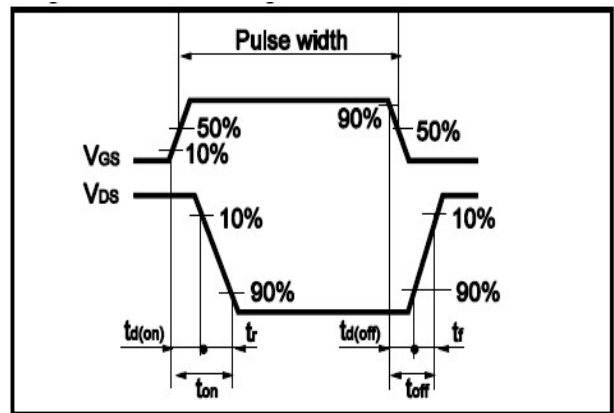

Fig.11 Avalanche Measurement Circuit

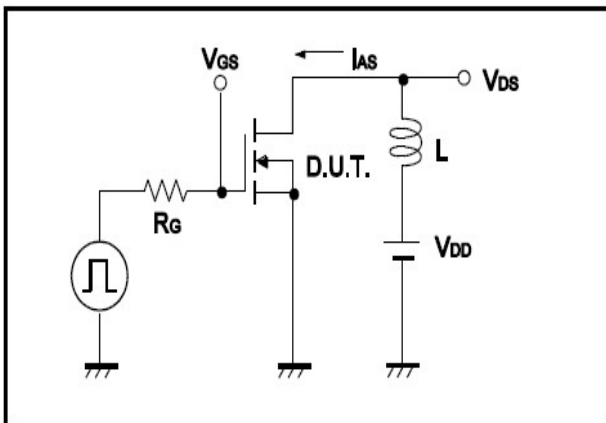
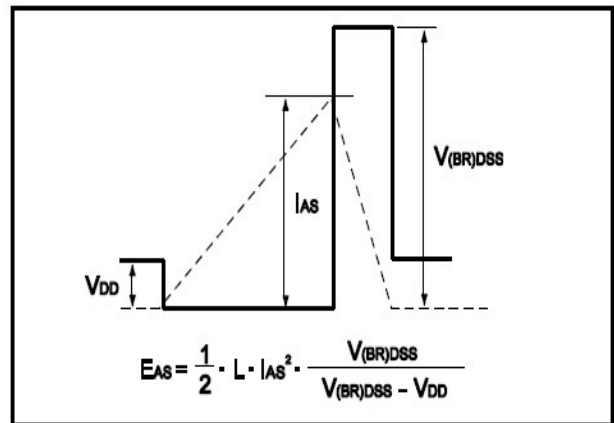
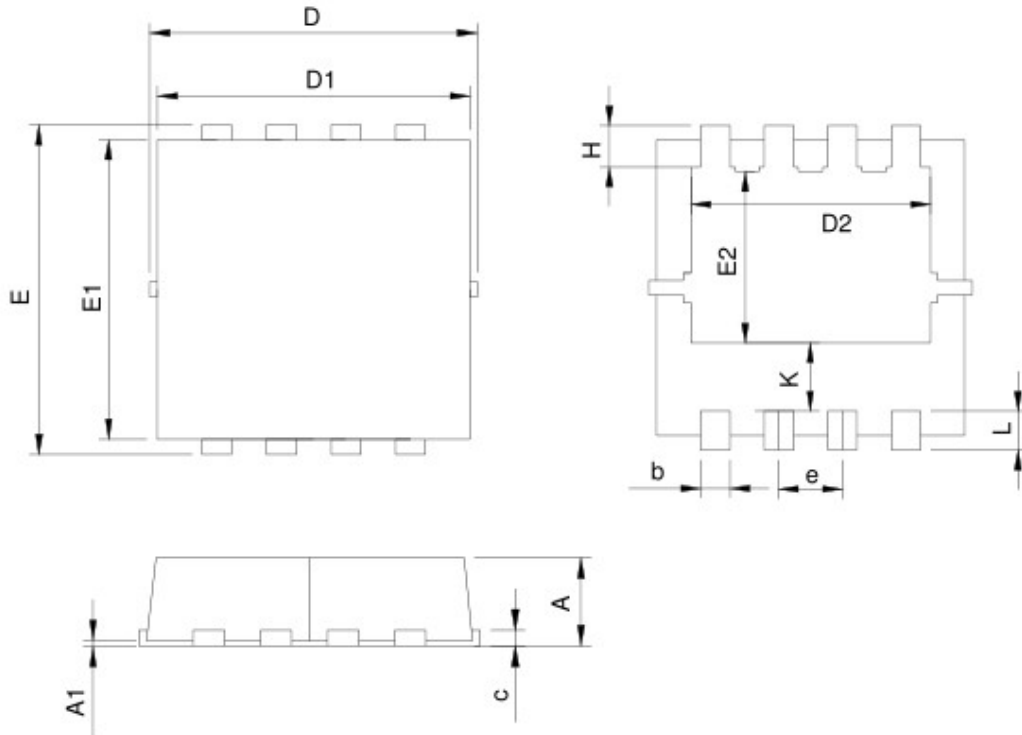

Fig.12 Avalanche Waveform





SYMBOL	DFN3.3x3.3-8			
	MILLIMETERS		INCHES	
	MIN.	MAX.	MIN.	MAX.
A	0.70	1.00	0.028	0.039
A1	0.00	0.05	0.000	0.002
b	0.25	0.35	0.010	0.014
c	0.14	0.20	0.006	0.008
D	3.10	3.50	0.122	0.138
D1	3.05	3.25	0.120	0.128
D2	2.35	2.55	0.093	0.100
E	3.10	3.50	0.122	0.138
E1	2.90	3.10	0.114	0.122
E2	1.64	1.84	0.065	0.072
e	0.65 BSC		0.026 BSC	
H	0.32	0.52	0.013	0.020
K	0.59	0.79	0.023	0.031
L	0.25	0.55	0.010	0.022

RECOMMENDED LAND PATTERN

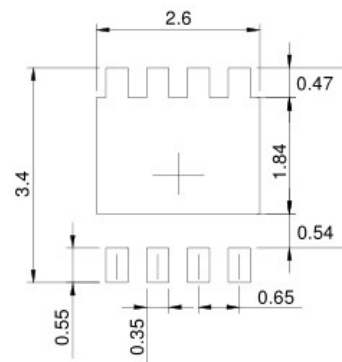

UNIT: mm